



**Hollymatic.**

*The Power Of The Dealer Network*

## Hollymatic 175 Mixer/Grinder



### Specifications:

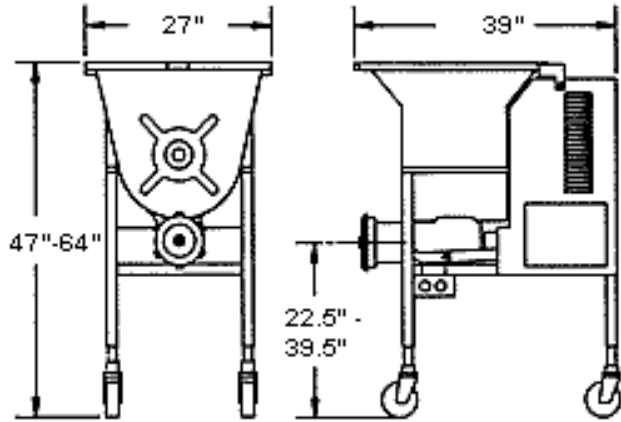

**175**

### 175 & 180A Standard Features

- 7-1/2 H.P. motor
- #42 grinder head
- Swing open tub
- Safety interlocked lid
- Front controls
- Adjustable legs
- Meat deflector
- Inspection holes in lid
- Protected electrical system
- Automatic electrical overload reset
- 4 swivel casters with locks

### Optional Features

- 5 H.P. motor (175 GMG)
- 10 H.P. motor (180A GMG)
- #52 grinder head
- Gemini connections
- Pneumatic footswitch
- 2nd grind mixing paddles (180A GMG)
- High elevation legs (180A GMG)

### Performance

- 175 GMG: Final grind-100 lbs. per minute through #52 head
- 180A GMG: Up to 120 lbs. per minute with #52 grinder head and 2nd grind paddles

### Net Weight

- 530 lbs. (175 GMG) 825 lbs. (180A GMG)

### Available Voltages

		<b>175 GMG</b>	<b>180A GMG</b>
5 H.P.	200V, 60Hz, 3 ph	16.2A	N/A
	230/460 V, 60 Hz, 3 ph	14.2/7.1 A	N/A
7 1/2 H.P.	200V, 60Hz, 3 ph	22.9 A	25A
	230/460 V, 60 Hz, 3 ph	19.6/9.8 A	22/11 A
10 H.P.	200V, 60Hz, 3 ph	N/A	31 A
	230/460 V, 60 Hz, 3 ph	N/A	28/14 A
575 V, 60Hz, 3 ph and 230/380V. 50 Hz, 3ph also available.			